

15V 54A Full Brick Battery-Charging Converter



CE

Features

- High efficiency and excellent thermal performance
- Programmable output current limit
- Input under-voltage, output over-voltage, over-current, and over-temperature protections
- Reinforced insulation, 4,250Vdc input to output isolation
- IPC-9592 Qualification/Screening
- Wide operating temperature range from -40°C to +100°C

Part Numbering System

FYU	EB	150	□	054	□	□	□	-	H
Series Name	Input Voltage	Output Voltage	Enabling Logic	Rated Output Current	Pin Length	Options 1	Options 2	-	Operating Temperature Grade (°C)*
	EB: 200-420V	Example: 150: 15V	P: Positive N: Negative	Example: 054: 54A	N: 0.130" R: 0.165"	0: Latch off 2: Auto-restart	P: Standard		H: -40 to +100

* Operating temperature is the temperature measured at the center of the baseplate.

Absolute Maximum Rating

Excessive stresses over these absolute maximum ratings can cause permanent damage to the converter. Operation should be limited to the conditions outlined under the Electrical Specification section.

Parameter	Min	Max	Unit
Input Voltage (continuous operating)	-0.5	420	V
Input Voltage (continuous, non-operating)	-	450	V
Input Voltage (<100ms, operating)	-	500	V
Storage Temperature	-55	125	°C

Electrical Specifications

These specifications are valid over the converter's full range of input voltage, resistive load, and temperature unless noted otherwise.

Input Specifications

Parameter	Min	Typical	Max	Unit
Input Voltage	200	270	420	V
Input Current	-	-	6	A
Quiescent Input Current (typical Vin)	-	45	75	mA
Standby Input Current	-	6	8	mA
Input Turn-on Voltage Threshold	180	185	190	V
Input Turn-off Voltage Threshold	170	175	180	V

Output Specifications

Parameter	Min	Typical	Max	Unit
Output Voltage Set Point (typical Vin; full load; Ta = 25°C)	-	15	-	V
Output Voltage Set Point Accuracy (typical Vin; full load; Ta = 25°C)	-1.5	-	+1.5	%Vo
Output Voltage Set Point Accuracy (over all conditions)	-3.0	-	+3.0	%Vo
Output Regulation:				
Line Regulation (full range input voltage, 1/2 full load)	-	0.2	0.5	%Vo
Load Regulation (full range load, typical Vin)	-	0.2	0.5	%Vo
Temperature (Ta = -40°C to 85 °C)	-	0.1	-	%Vo
Output Ripple and Noise Voltage RMS	-	40	50	mVrms
Peak-to-peak (5 Hz to 20 MHz bandwidth, typical Vin)	-	120	150	mVp-p
Output Current	0	-	54	A
Output Power	0	-	810	W
Efficiency (full load; Ta = 25°C)	-	92.0	-	%
Output Ripple Frequency	235	250	265	kHz
External Load Capacitance (typical Vin)	-	-	20,000	µF

Output Specifications (Continued)

Parameter	Min	Typical	Max	Unit
Output Over Voltage Protection Set Point	16.8	17.8	19.0	V
Output Voltage Trim Range	9	-	15	V
Output Under-Voltage Shutdown (when the output voltage drops below the minimum voltage specified in the Output Voltage Trim Range)	-	-	9	V
Dynamic Response (typical V_{in} ; $T_a = 25^\circ\text{C}$; load transient $0.1\text{A}/\mu\text{s}$) Load steps from 50% to 75% of full load:				
Peak deviation		2		% V_o
Settling time (within 10% band of V_o deviation)		300		μs
Load step from 50% to 25% of full load				
Peak deviation		2		% V_o
Settling time (within 10% band of V_o deviation)		300		μs

General Specifications

Parameter	Min	Typical	Max	Unit
Remote Enable				
Logic Low:				
$I_{ON/OFF} = 1.0\text{mA}$	0	-	1.2	V
$V_{ON/OFF} = 0.0\text{V}$	-	-	1.0	mA
Logic High:				
$I_{ON/OFF} = 0.0\mu\text{A}$	3.5	-	15	V
Leakage Current	-	-	50	μA
Isolation Voltage: Input-Output	-	-	4,250	Vdc
Isolation Capacitance	-	2,350	-	pF
Insulation Resistance	10	-	-	M Ω

Feature Descriptions

Remote ON/OFF

The converter can be turned on and off by changing the voltage between the ON/OFF pin and Vin(-). The FYUEB Series of converters is available with factory selectable positive logic and negative logic.

For the negative control logic, the converter is ON when the ON/OFF pin is at a logic low level and OFF when the ON/OFF pin is at a logic high level. For the positive control logic, the converter is ON when the ON/OFF pin is at a logic high level and OFF when the ON/OFF pin is at a logic low level.

With the internal pull-up circuitry, a simple external switch between the ON/OFF pin and Vin(-) can control the converter. A few example circuits for controlling the ON/OFF pin are shown in Figures 1, 2 and 3.

The logic low level is from 0V to 1.2V and the maximum sink current during logic low is 1mA. The external switch must be capable of maintaining a logic-low level while sinking up to this current. The logic high level is from 3.5V to 15V. The converter has an internal pull-up circuit that ensures the ON/OFF pin at a high logic level when the leakage current at ON/OFF pin is no greater than 50µA.

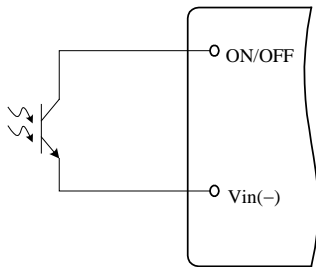

Figure 1. Opto Coupler Enable Circuit

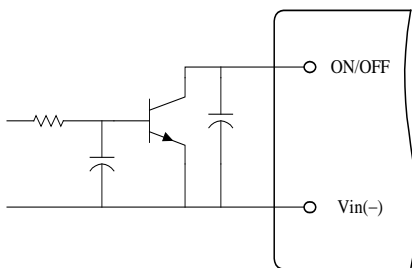

Figure 2. Open Collector Enable Circuit

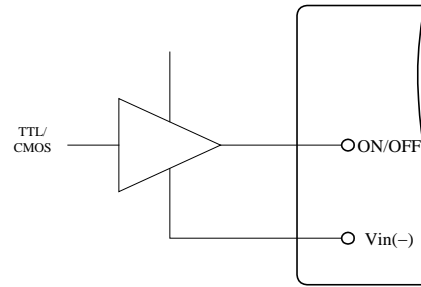

Figure 3. Direct Logic Drive

Output Voltage Adjustment

The trim pin allows the user to adjust the output voltage set point. To decrease the output voltage, an external resistor is connected between the trim pin and Vout(-). The output voltage trim range is 60% to 100% of the specified typical output voltage.

The circuit configuration for trim down operation is shown in Figure 4. To decrease the output voltage, the value of the external resistor should be

$$R_{\text{down}} = \left(\frac{205}{\Delta} - 5.21 \right) (\text{k}\Omega)$$

Where

$$\Delta = \left(\frac{|V_{\text{nom}} - V_{\text{adj}}|}{V_{\text{nom}}} \right) \times 100$$

And

V_{nom} = Typical Output Voltage

V_{adj} = Adjusted Output Voltage

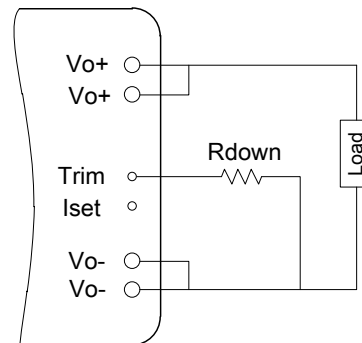

Figure 4. Circuit to Decrease Output Voltage

Programmable Output Current Limit

The default output current limit is set to the maximum output current specified in Output Specifications, and

it can be programmed down to 3A. To program the output current limit, a resistor shall be connected between Iset pin and Vout(-) pin; The circuit configuration is shown in Figure 5.

$$RI_{set} = \left(\frac{5110}{\Delta} - 52.1 \right) K\Omega$$

Where

$$\Delta = \left(\frac{I_{nom} - I_{set}}{I_{nom}} \right) \times 100$$

And

I_{nom} = Typical Output Current

I_{set} = Desired Output Current Set Point

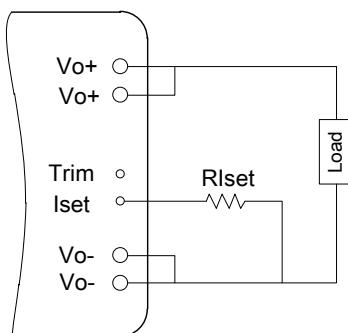

Figure 5. Program Constant Output Current Set Point

Input Under-Voltage Lockout

This feature prevents the converter from starting until the input voltage reaches the turn-on voltage threshold, and keeps the converter running until the input voltage falls below the turn-off voltage threshold. Both turn-on and turn-off voltage thresholds are defined in Input Specifications.

Output Under-Voltage Shutdown

With the auto-restart option, the converter enters a hiccup mode (repeatedly shuts down and restarts) if its output voltage is pulled below 9V. The converter automatically resumes normal operation when the under-voltage condition is cleared.

With the latch-off option, the converter shuts down and latches off when its output voltage is pulled below 9V. The converter can be restarted by recycling the ON/OFF signal or the input voltage.

Output Over-Voltage Protection (OVP)

This converter can be ordered in either latch-off or auto-restart version upon OVP, and OTP.

With the latch-off version, the converter will latch off when the output voltage exceeds the limit. The converter can be restarted by toggling the ON/OFF switch or recycling the input voltage.

With the auto-restart version, the converter will operate in a hiccup mode (repeatedly try to restart) until the cause of the over-voltage condition is cleared.

Over Temperature Protection (OTP)

The converter has a temperature sensor located at a carefully selected position, which represents the thermal condition of the key components. A thermal shutdown circuit turns the converter off when the sensed temperature reaches 120°C.

With the auto-restart option, the converter shuts down when the temperature exceeds 120°C, and resumes normal operation after the converter cools down.

With the latch-off option, the converter shuts down and latches off when the temperature exceeds 120°C. The converter can be restarted by recycling the ON/OFF signal or the input voltage.

Design Considerations

As with any DC-DC converter, the stability of the FYUEB converter may be compromised if the source impedance is too high or inductive. It's desirable to keep the input source ac-impedance as low as possible. Although the converters are designed to be stable without adding external input capacitors for typical source impedance, it is recommended to add 10μF low ESR electrolytic capacitors at the input of the converter for each 100W output power, which reduces the potential negative impact of the source impedance on the converter stability. These electrolytic capacitors should have sufficient RMS current rating over the operating temperature range.

The converter is designed to be stable without additional output capacitors. To further reduce the output voltage ripple or improve the transient response, additional output capacitors are often used in applications. When additional output capacitors are used, a combination of ceramic capacitors and tantalum/polymer capacitors shall be used to provide good filtering while assuring the stability of the converter.

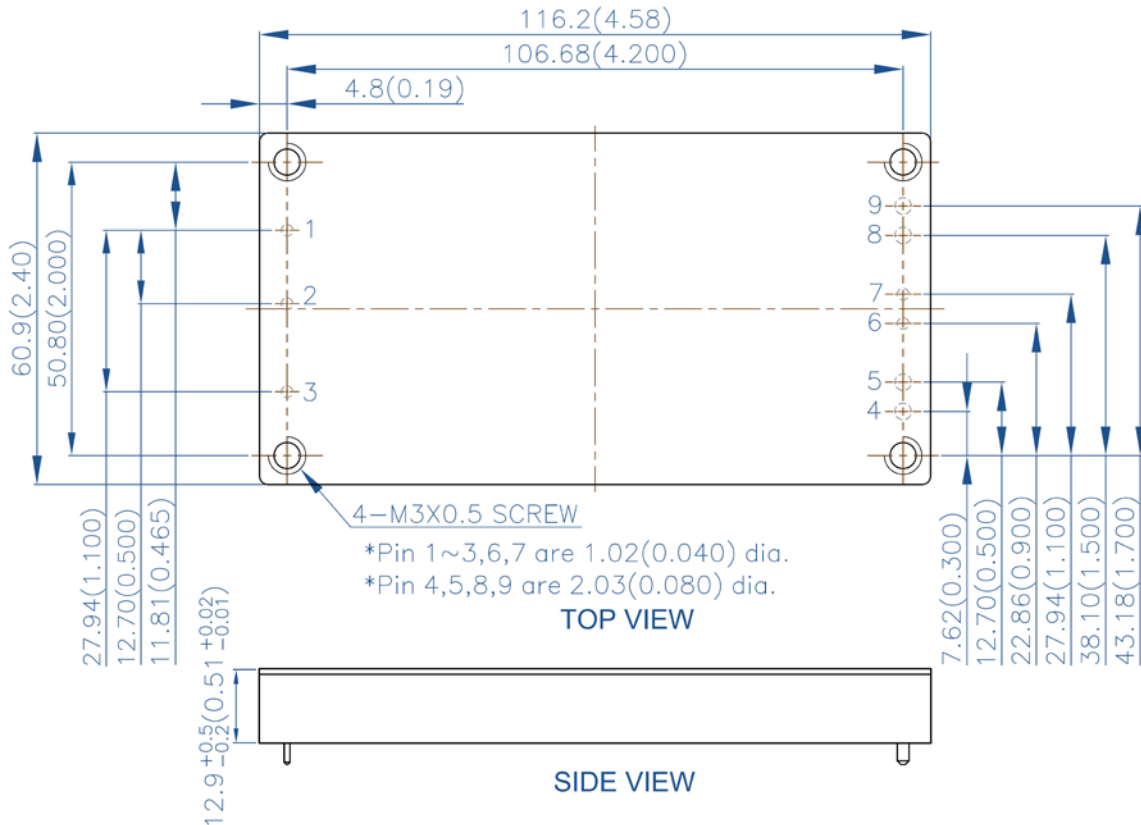
Mechanical Drawing

Pin	Name	Function
1	Vin(+)	Positive input voltage
2	ON/OFF	Remote control
3	Vin(-)	Negative input voltage
4	Vout(-)	Negative output voltage
5	Vout(-)	Negative output voltage
6	Iset	Set output current
7	TRIM	Output voltage adjustment
8	Vout(+)	Positive output voltage
9	Vout(+)	Positive output voltage

Notes:

- All dimensions in mm (inches)
Tolerances: .x ± .5 (.xx ± 0.02)
.xx ± .25 (.xxx ± 0.010)
- Input and function pins are 1.02mm (0.040") dia. with +/- 0.10mm (0.004") tolerance. The recommended diameter of the receiving hole is 1.42mm (0.056").
- Output pins are 2.03mm (0.080") dia. with +/- 0.10mm (0.004") tolerance. The recommended diameter of the receiving hole is 2.44mm (0.096").
- All pins are Copper Alloy, Matte Tin finish with Nickel under plating.
- Typical weight: 310g.
- Workmanship meets or exceeds IPC-A-610 Class II.
- Torque applied on screw should not exceed 6in-lb. (0.7 Nm).
- Baseplate flatness tolerance is 0.10mm (0.004") TIR for surface.